

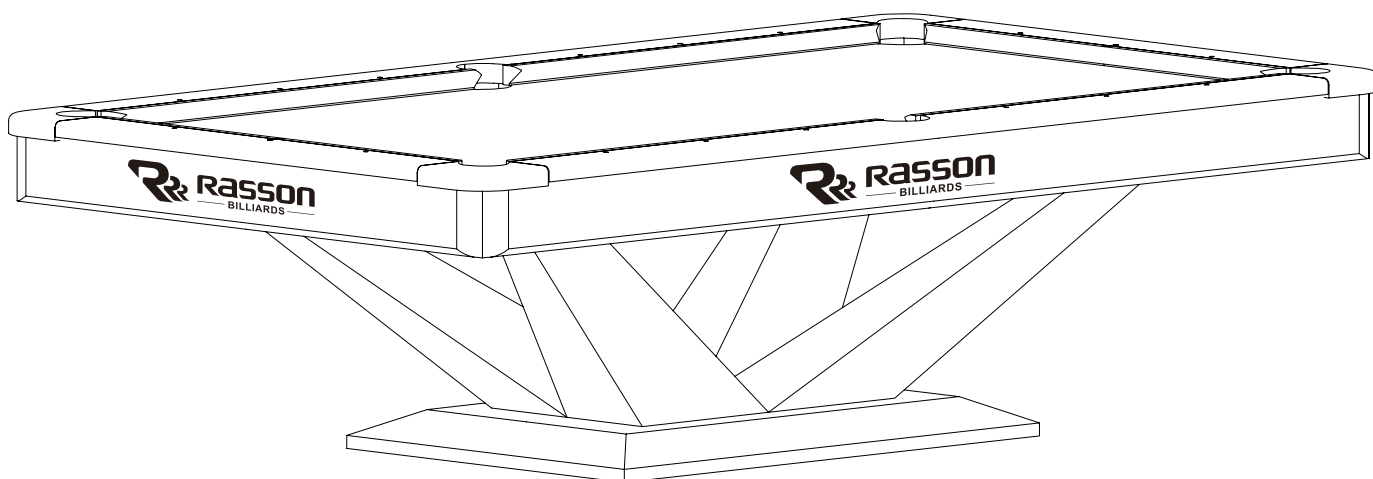

















V 勝利
VICTORY









BILLIARDS INSTRUCTION MANUAL







REPLACEMENT PARTS LIST (HARDWARE)

PACKAGE	ITEM #	SAMPLE	DESCRIPTION	QTY.
LEG/PAD	H1		DOUBLE-THREAD SCREW	16
	H2		FLAT WASHER 1/2" I.D.	16
	H3		HEX NUT 1/2" I.D.	16
	H4		HEX HEAD CROSS BOLT 3/8" x 3-1/8"(M10 x 80mm)	8
	H5		FLAT WASHER 3/8" I.D.	8
CABINET	H6		HEX HEAD CROSS BOLT 3/8" x 3-1/8"(M10 x 80mm)	8
	H7		FLAT WASHER 3/8" I.D.	8
	H8		HEX NUT 3/8" I.D.	8
RAIL/POCKET/FRAME/SLATE	H9		WOOD SCREW 3/8" x 2-1/4"(10 x 57mm)	12
	H10		HEX HEAD CROSS BOLT 3/8" x 1-3/8"(M10 x 35mm)	12
	H11		FLAT WASHER 3/8" I.D.	12
	H12		SMALL MACHINE SCREWS 1/4" x 11/16"(M6 x 17mm)	16
	H13		FLAT WASHER 1/4" I.D.	16
	H14		HEX HEAD CROSS BOLT 5/16" x 11/16"(M8 x 17mm)	54
	H15		FLAT WASHER 5/16" I.D.	54

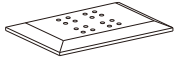
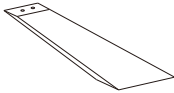
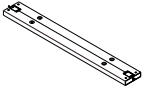
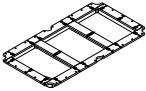
REPLACEMENT PARTS LIST (HARDWARE)

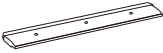
PACKAGE	ITEM #	SAMPLE	DESCRIPTION	QTY.
	H16		HEX HEAD CROSS BOLT 3/8" x 2-3/8" (M10 x 60mm)	30
	H17		FLAT WASHER 3/8" I.D.	60
	H18		SPRING LOCK WASHER 3/8" I.D.	30
	H19		PLASTIC BAYONET (WITHIN POCKET)	18
	H20		METAL BRACKET	18
	H21		WRENCH	1

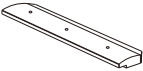
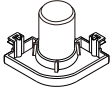
REPLACEMENT PARTS LIST

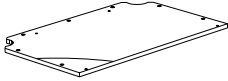
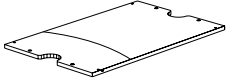
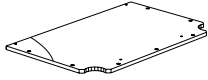
PACKAGE	ITEM #	SAMPLE	DESCRIPTION	QTY.
LEG/PAD	1		PEDESTAL	1
	2		LEG	4
TOP RAIL CABINET/FRAME	3		BEAM CONNECTS CABINET & LEG	2
	4		CABINET	1
	5		END APRON	2
	6		SIDE APRON	2
	7		TOP RAIL LEFT SIDE	2
	8		TOP RAIL RIGHT SIDE	2
	9		TOP RAIL END	2
POCKET	10		CORNER POCKET	4
	11		SIDE POCKET	2
SLATE	12		SLATE (LEFT)	1
	13		SLATE (CENTER)	1
	14		SLATE (RIGHT)	1

REPLACEMENT PARTS LIST



PACKAGE	ITEM #	SAMPLE	DESCRIPTION	QTY.
	15		CLOTH	1
	16		METAL CORNER	4

FIG.1

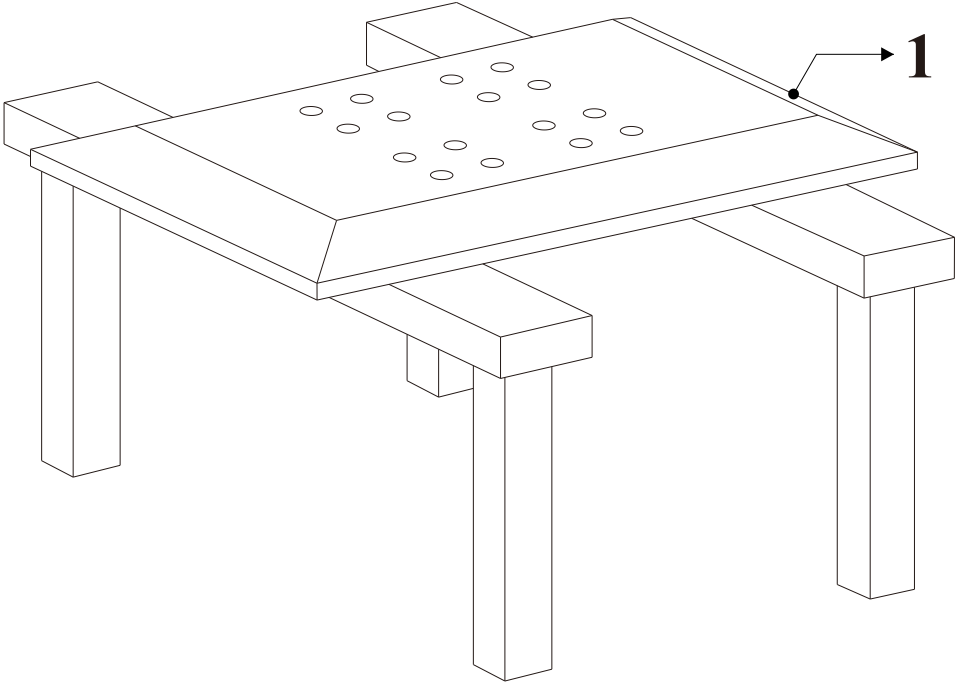

FIG.2

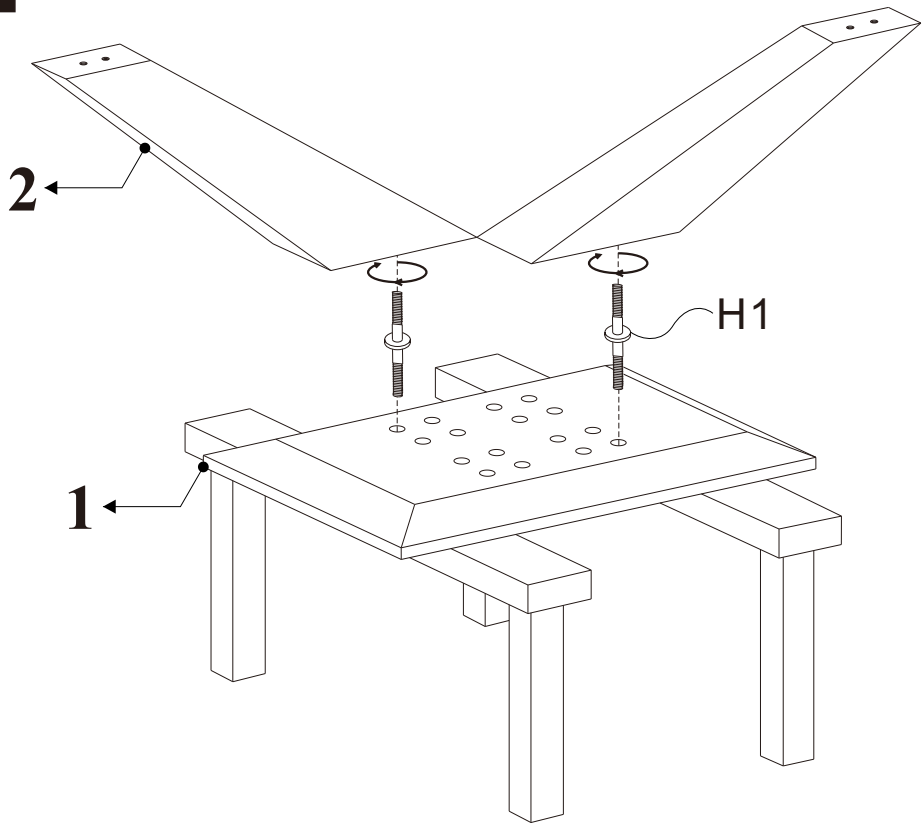

FIG.3

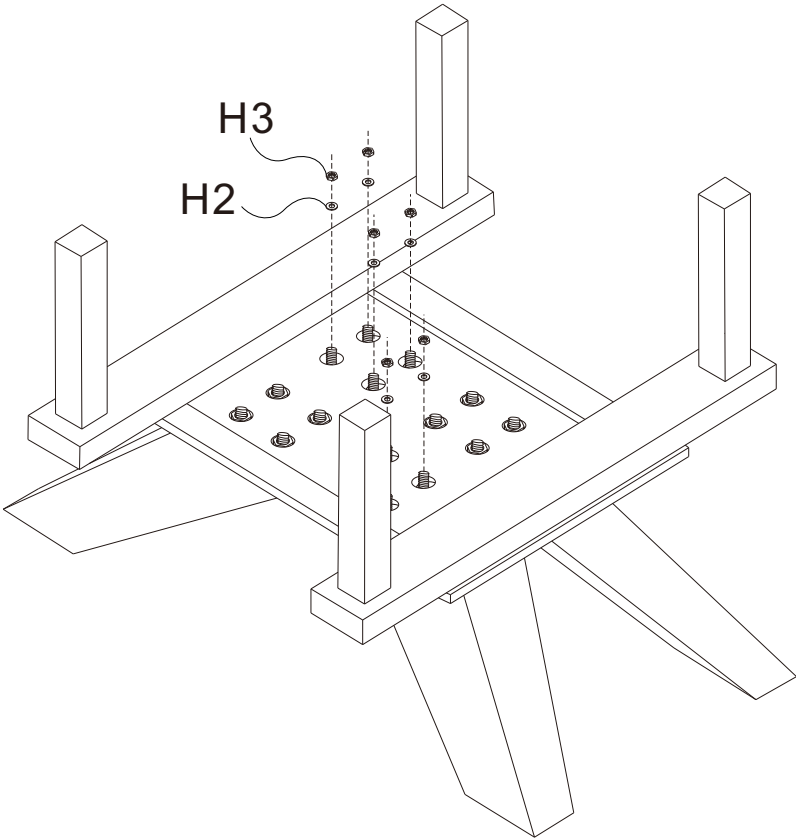

FIG.4

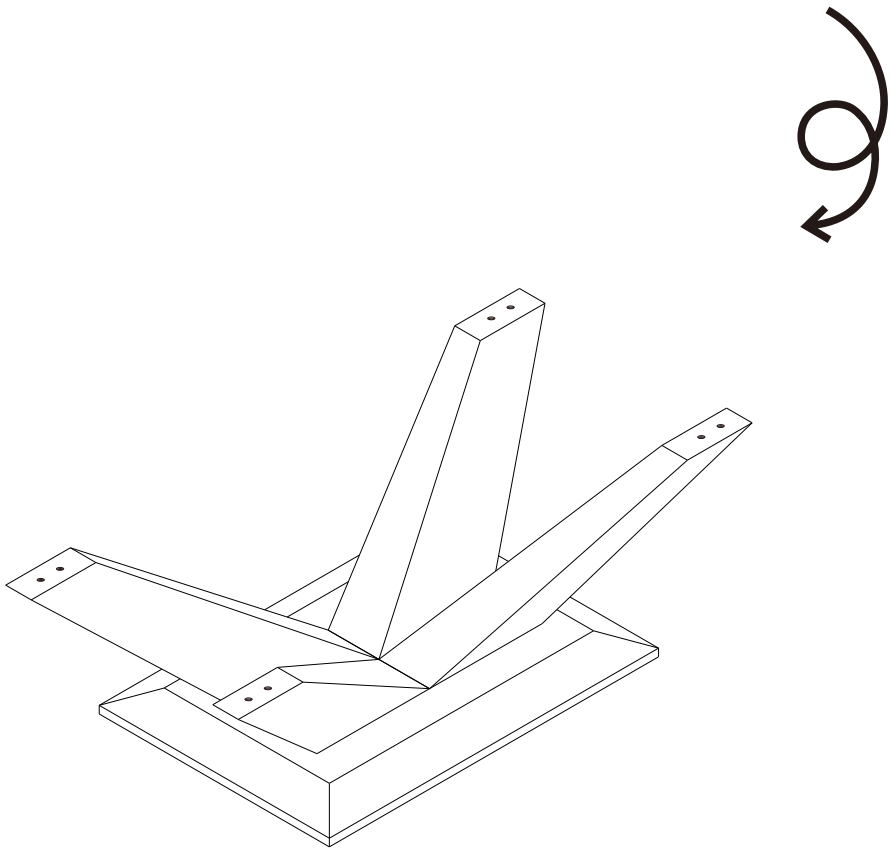
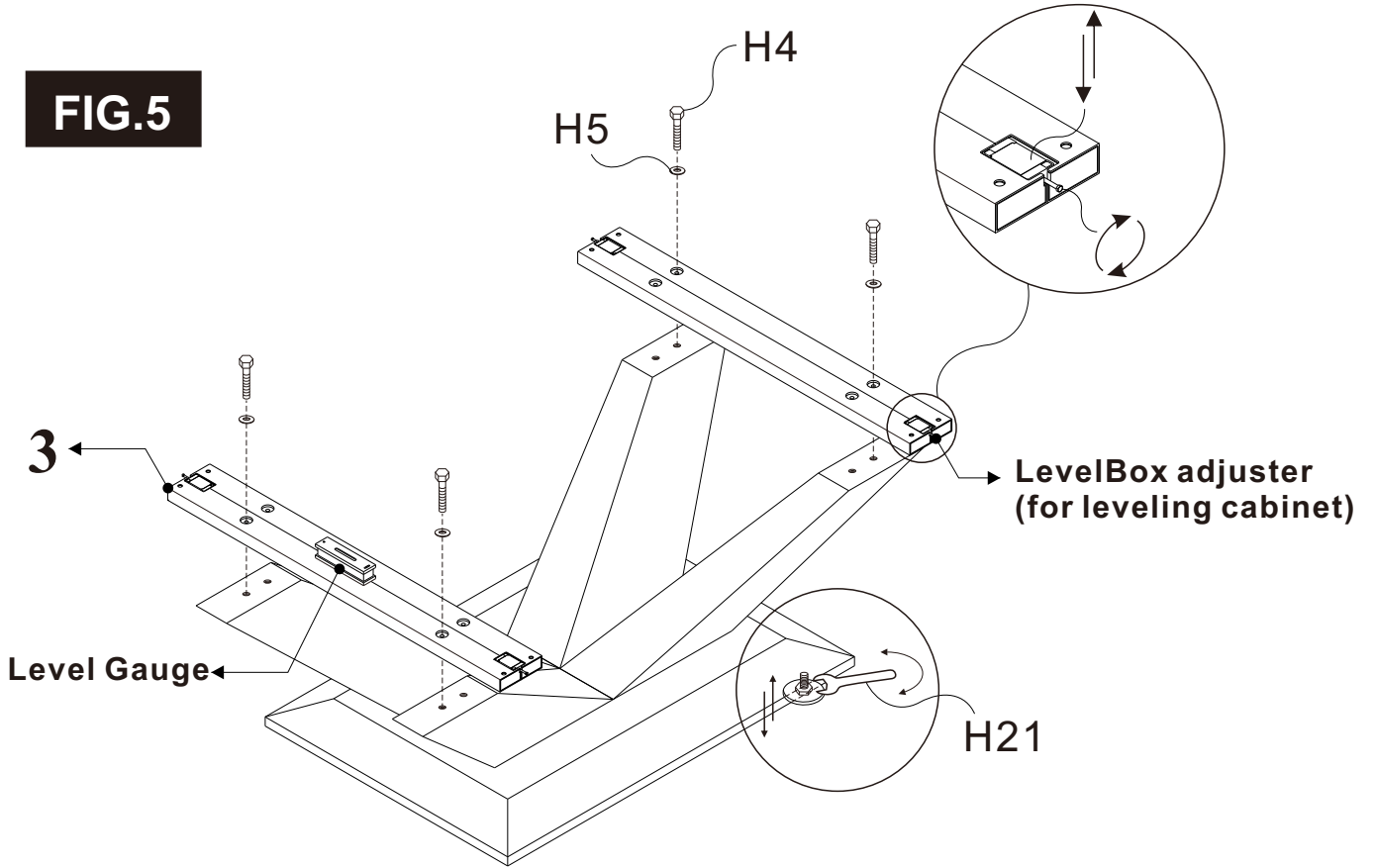

FIG.5



* Level **3** through levelers underneath the table base with H21, then tighten H4

FIG.6

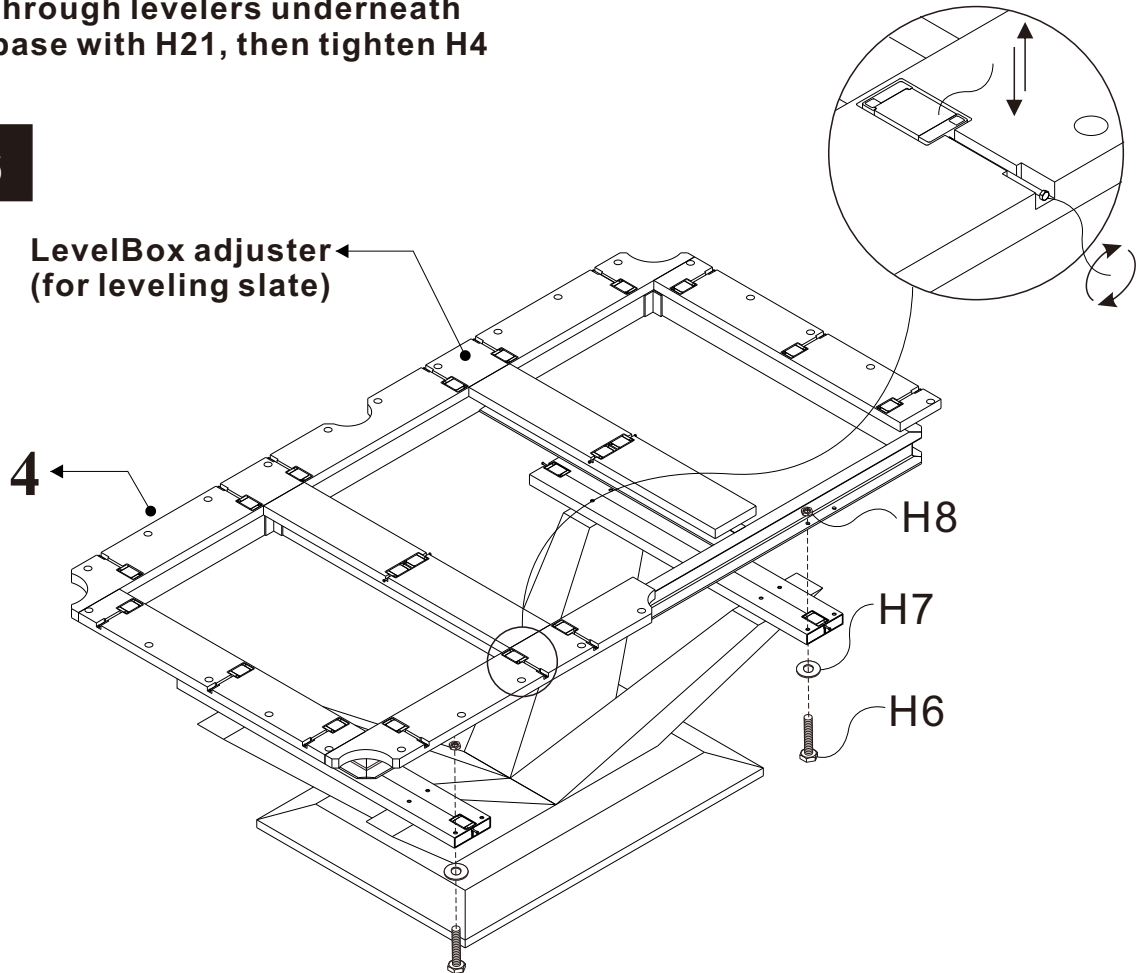
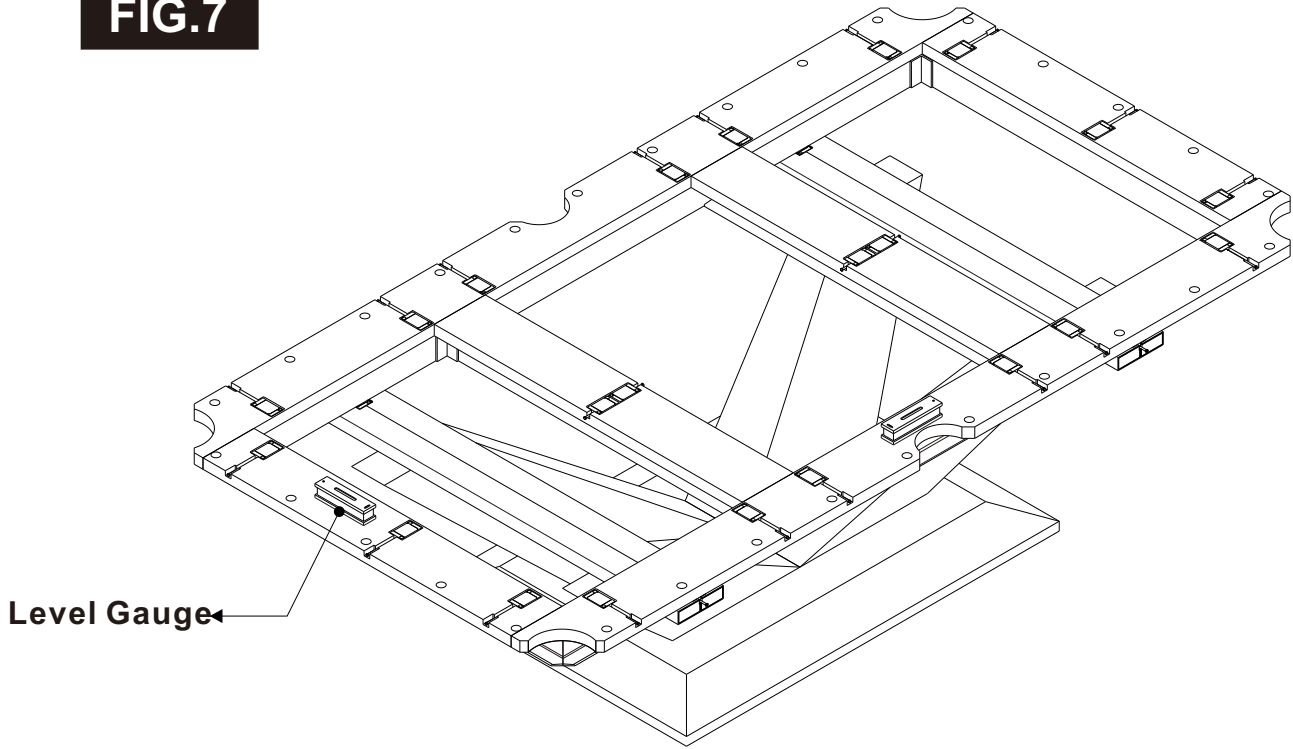

FIG.7



*** Level table cabinet with 4 LevelBox adjusters, then tighten the cabinet with H6 bolt**

FIG.8

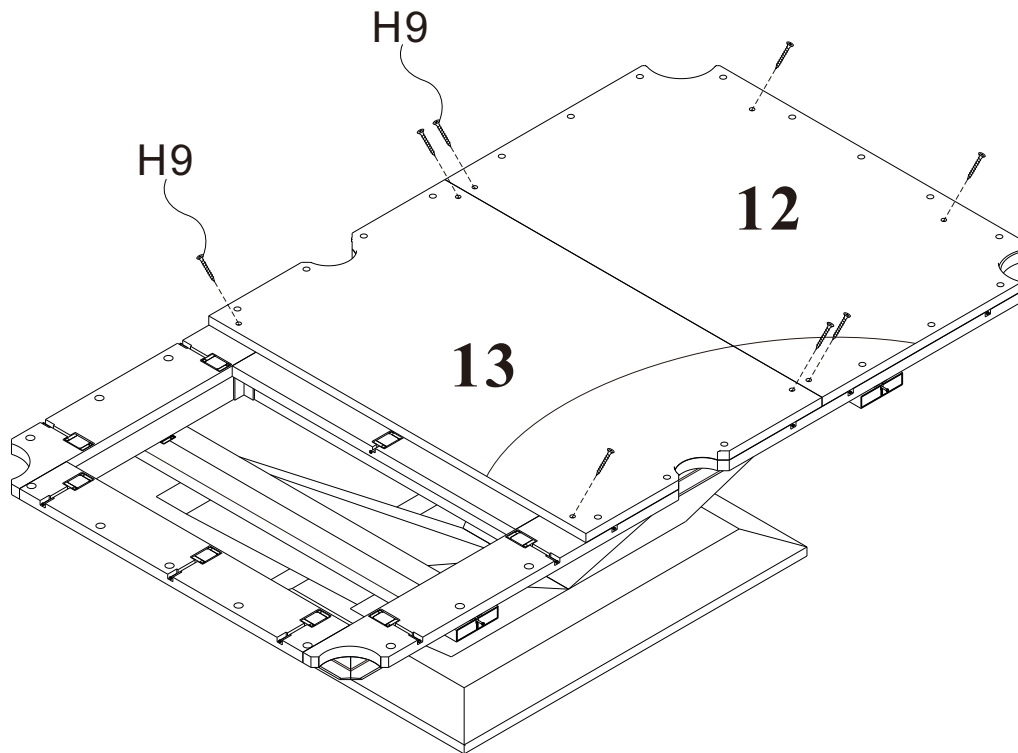
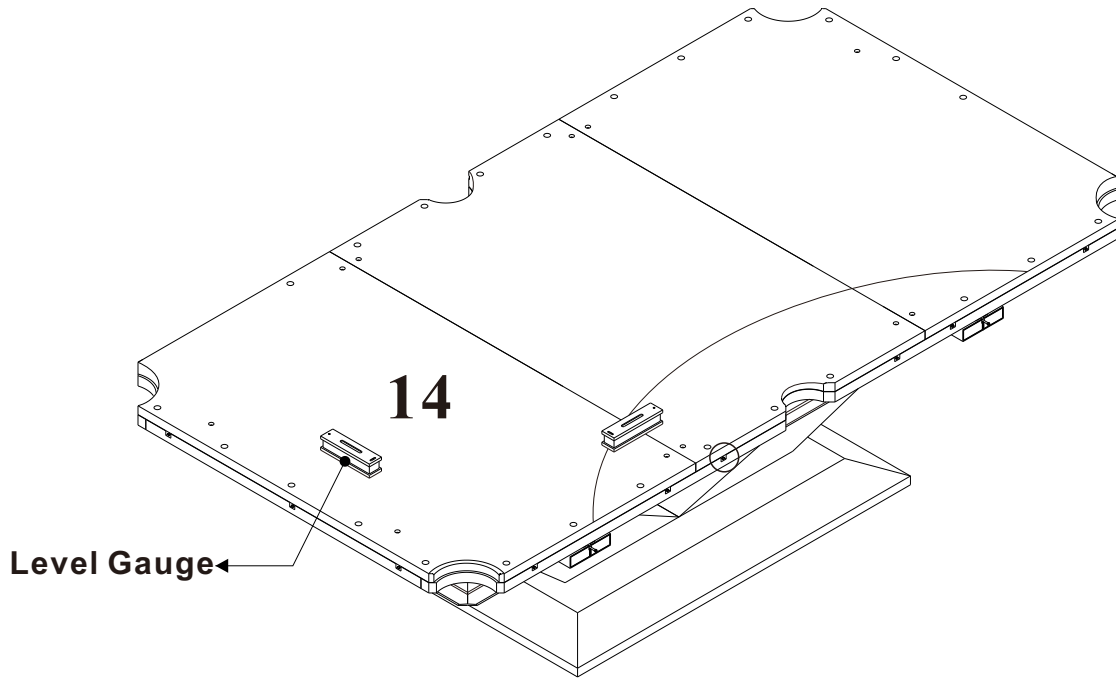

FIG.9



* Level slate with 22 LevelBox adjusters

FIG.10

* Attach the H14 on H20 (don't tighten the bolt)

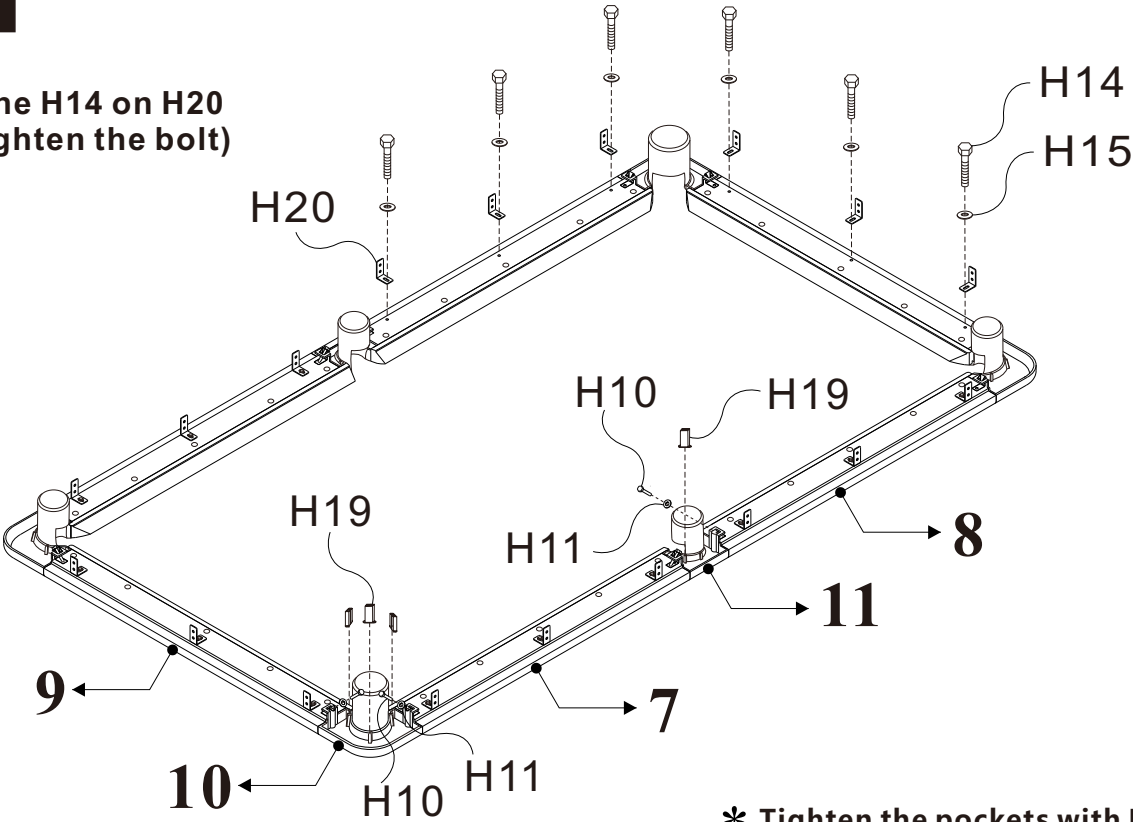

* Tighten the pockets with H17

FIG.11

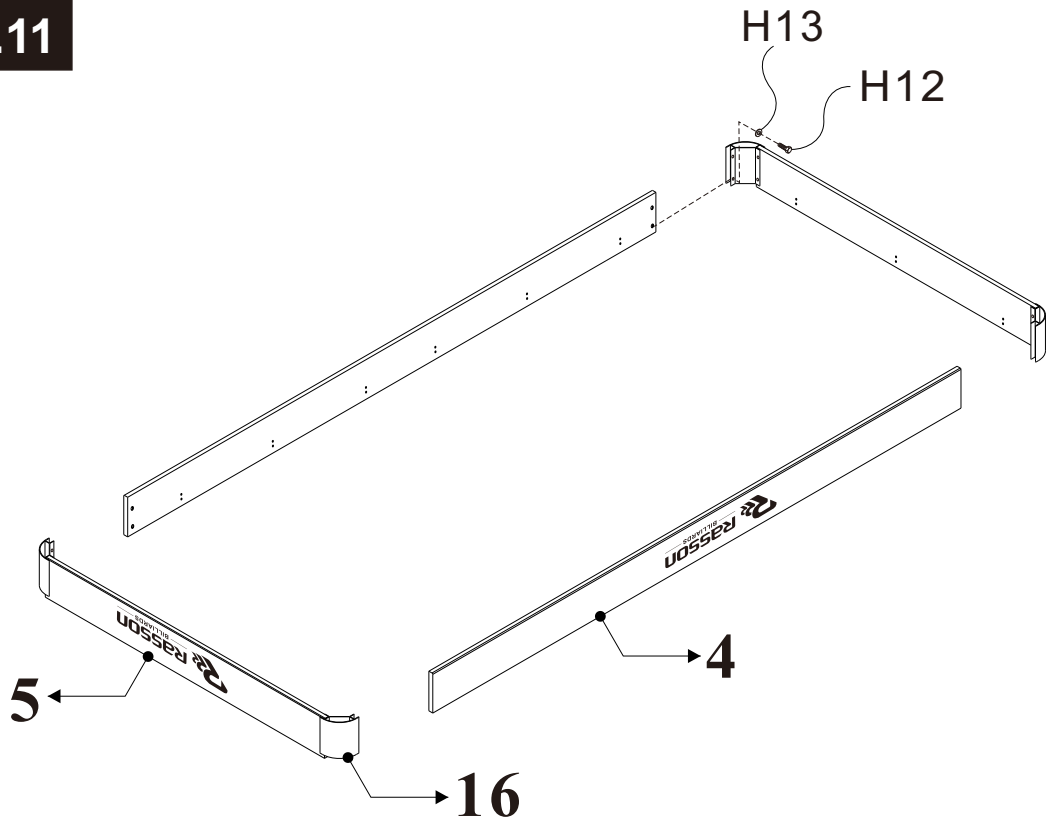

FIG.12

* Tighten H14 after Apron be assembled

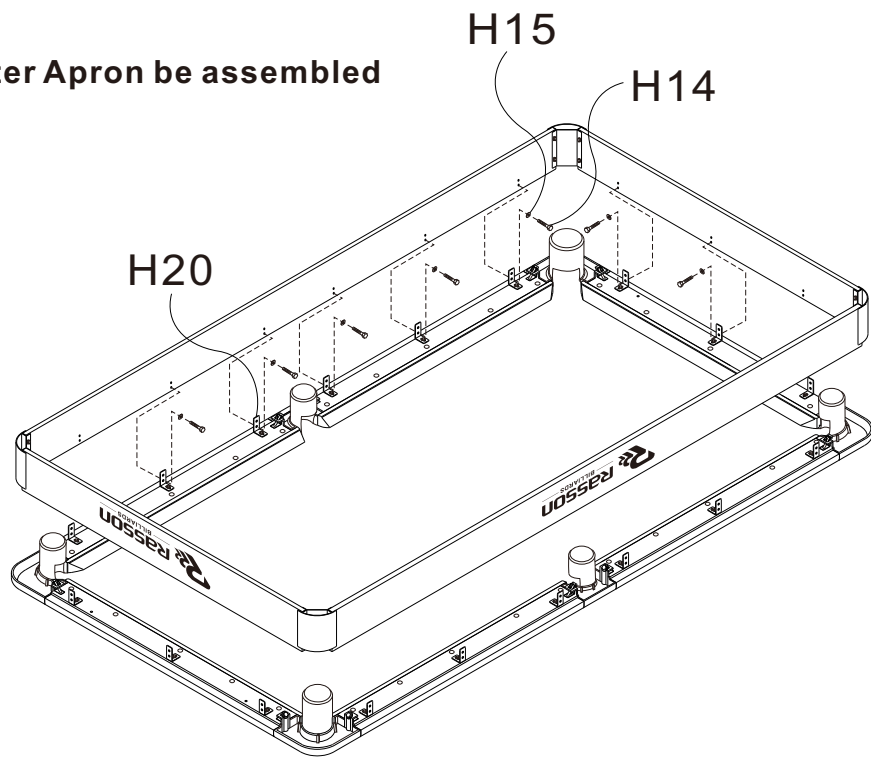
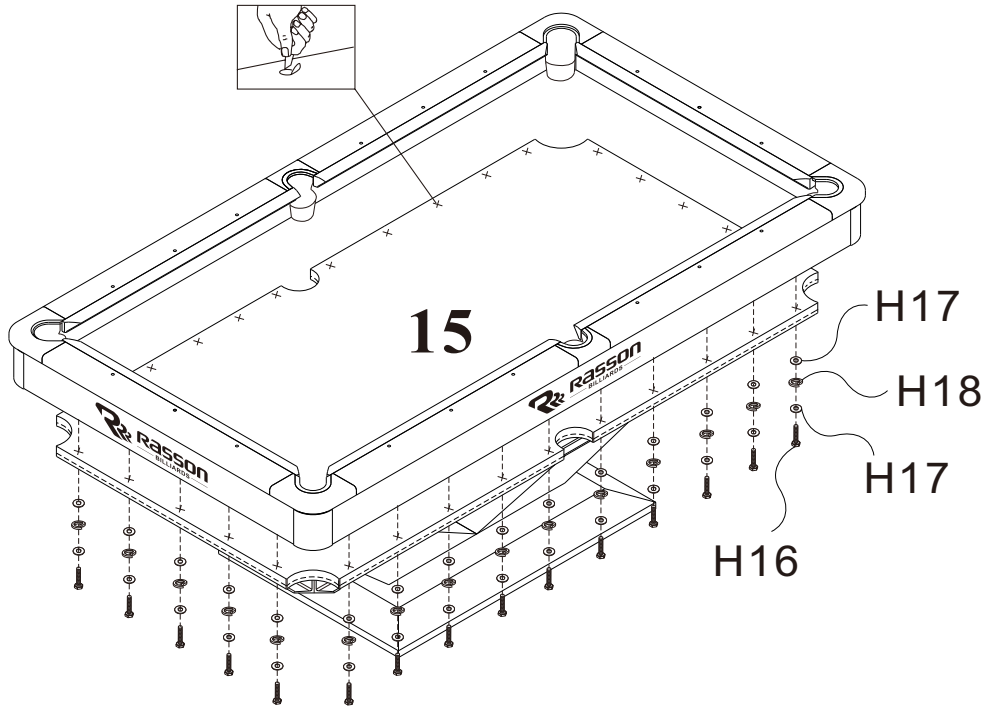

FIG.14

Cut holes in cloth at rail both locations.



*** Please MUST press down the pockets and make them underneath the slate to prevent balls from bouncing out**

FINISH

